

XJ Transmitter Series

XJ2 & XJ22 (2 Wire) Universal Input



XJ2
Single Transmitter



XJ22
Dual Transmitter

Features.

Field Programmable Bi-Polar Input Ranges.

Input types:

- mV, V, & mA.
- RTD Pt100.
- Differential RTD.
- Thermopouple (T/C).
- Bridge/Strain Gauge.
- Potentiometer.
- Resistance.

Input to Output Isolation 2kV.

High Accuracy 0.1%.

Reverse Polarity Protected.

LED Indication of Current Loop (CL).

Compact DIN Rail Mount Enclosure.

Available With One or Two Transmitters per Enclosure.

Available Standard or Special Calibration.

Easy to Install.

Low Cost.

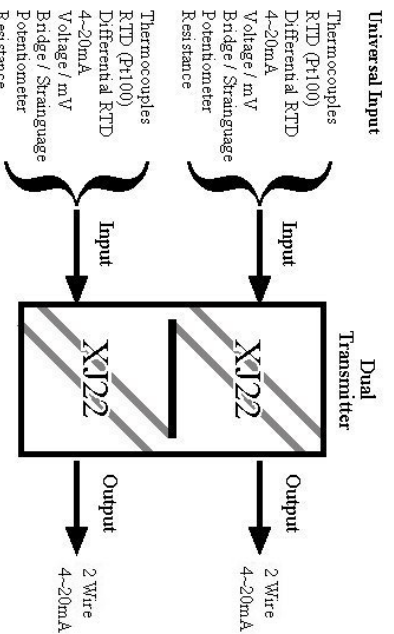

XJ4 (4 Wire) Universal Input



XJ4

Features.

Field Programmable Bi-polar Input and Output Ranges.

Input types:

- mV, V, & mA.
- RTD Pt100.
- Differential RTD.
- Thermopouple (T/C).
- Bridge/Strain Gauge.
- Potentiometer.
- Resistance.

Input to Output Isolation 2.0kV.

High Accuracy 0.1%.

Universal AC/DC Power Supply.

Transmitter Power Supply.

Compact DIN Rail Mount Enclosure.

Available Standard or Special Calibration.

Low Cost.

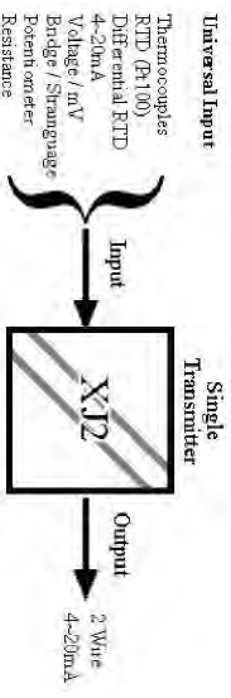
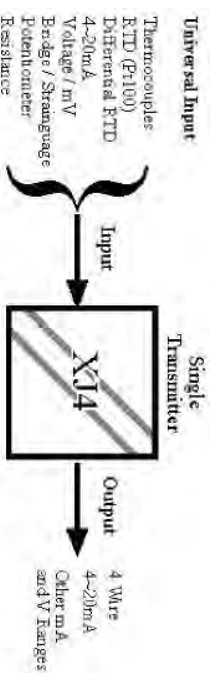

All this with high accuracy and stability.

TERMINAL CONFIGURATION

XJ2

XJ2, XJ22 Common Specifications

Output	2 wire 4~20mA. (Loop Powered.)
Power Supply	8~40Vdc.
Supply Voltage Sensitivity	<±0.005%/V FSO.
Output Load Resistance	800Ω @ 24Vdc. (50Ω/V Above 8Vdc.)
Maximum Output Current	Limited to <28mA.
EMC Emissions Compliance	EN 55022-A
EMC Immunity Compliance	EN 50082-1
Safety Compliance.	EN 60950
Accurate to	<±0.1% FSO Typical.
Linearity & Repeatability	<±0.1% FSO Typical. (Unless Individual Specifications State Otherwise.)
Ambient Drift	<±0.02%/C FSO Typical.
Noise Immunity	125dB CMRR Average. (2.0kVdc Limit.)
R.F. Immunity	<1% Effect FSO Typical.
Signal Isolation Test Voltage	Between Input and Output 2.0kVdc for 1 min.
XJ22 Isolation Test Voltage	Between the two XJ2 transmitters 2.0kVdc for 1 min.
Response Time	200msec Typical. (From 10 to 90% 50msec Typical.)
Operating Temperature	0~70C.
Storage Temperature	-20~80C.
Operating Humidity	5~85%RH Max. Non-Condensing.
Mounting	35mm Symmetrical Mounting Rail.
Dimensions	L=100, W=22.5, H=100mm.

XJ2, XJ22 Input / Output Drawings.

XJ22 contains 2 fully isolated Transmitters per enclosure.

XJ2-B Bridge/mV Input.

Connection Example.

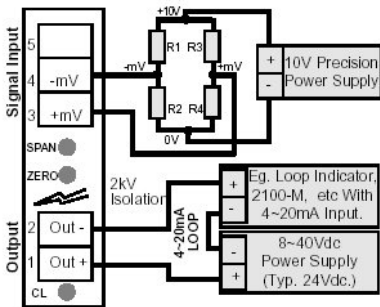

XJ2-D DC Voltage Input.

Connection Example.

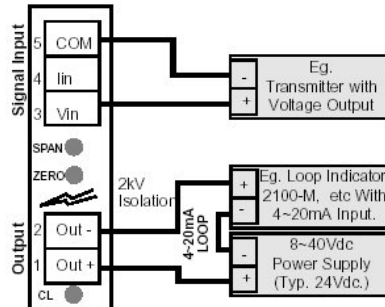

XJ2-D DC Current Input.

Connection Example.

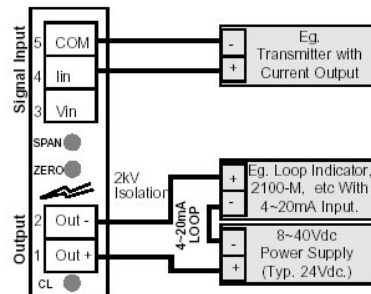

XJ4

XJ4 Common Specifications

Output	-Voltage	Field Programmable From 5V to ±10Vdc. Maximum Output Drive = 20mA. (500Ω maximum load @ 10Vdc.)
	-Current	Field Programmable From 10mA to ±20mAdc. Maximum Output Drive = 10.4Vdc. (520Ω@20mA.)(770Ω: 2Q 2004)
Universal P/S:	-H	85~265Vac/dc; 50/60Hz; 5VA.
	-M	22~90Vdc; 50/60Hz; 5VA.
	-L	10~28Vdc; 50/60Hz; 5VA.
	-Circuit Sensitivity	<±0.001%/V FSO Typical.
EMC Emissions Compliance	EN 55022-A	
EMC Immunity Compliance	EN 50082-1	
Safety Compliance.	EN 60950	
Accurate to		<±0.1% FSO Typical.
Linearity & Repeatability		<±0.1% FSO Typical.(Unless Individual Specifications State Otherwise.)
Ambient Drift		<±0.01%/C FSO Typical.
Noise Immunity		125dB CMRR Average. (2.0kVdc Limit.)
R.F. Immunity		<1% Effect FSO Typical.
Mains Isolation Test Voltage		To Input and Output 2300Vac, 50Hz for 1 min.
Signal Isolation Test Voltage		Between Input and Output 2.0kVdc for 1 min.
Response Time		200msec Typical. (From 10 to 90% 50msec Typical.)
Operating Temperature		0~60C.
Storage Temperature		-20~80C.
Operating Humidity		5~85%RH Max. Non-Condensing.
Mounting		35mm Symmetrical Mounting Rail.
Dimensions		L=100, W=22.5, H=100mm.

XJ4-B Bridge/mV Input.

Connection Example.

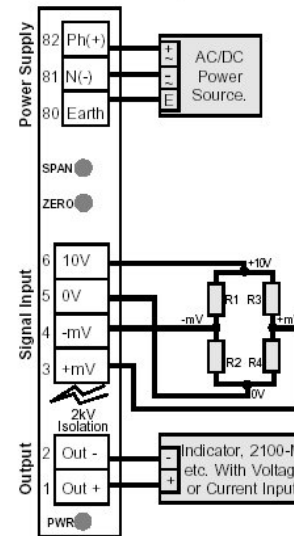

XJ4-D DC Voltage Input.

Connection Example.

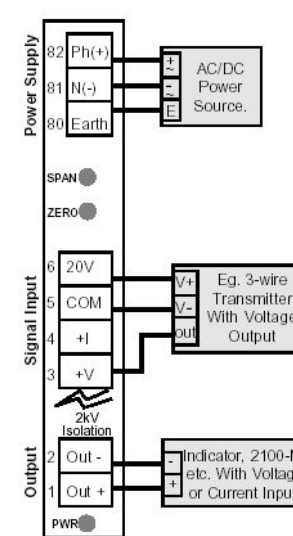

XJ4-D DC Current Input.

Connection Example.

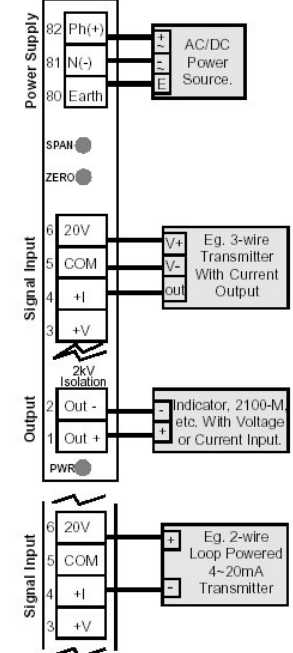

XJ2

XJ2-K Resistance Input.
Connection Example.

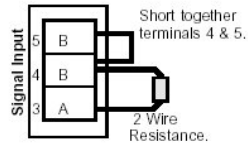
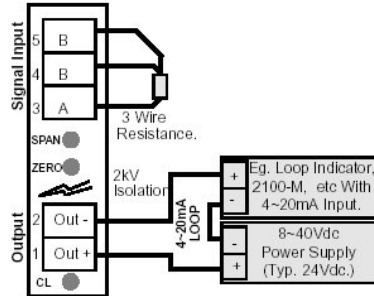

XJ2-P Potentiometer Input.
Connection Example.

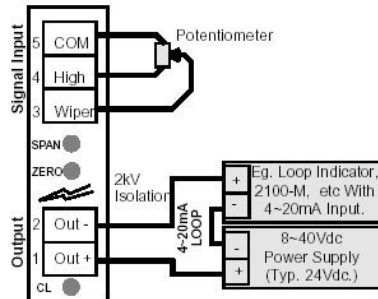

XJ2-T Thermocouple Input.
Connection Example.

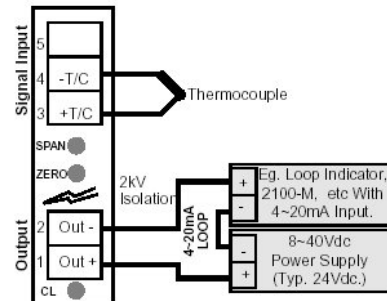

TERMINAL CONFIGURATION

XJ2-N Differential RTD Input.
Connection Example.

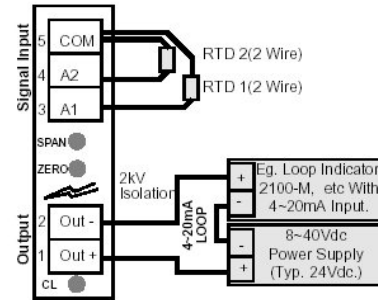

XJ2-R RTD Input.
Connection Example.

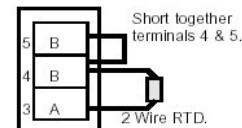
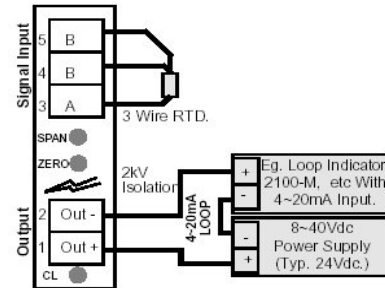

XJ4-K Resistance Input.
Connection Example.

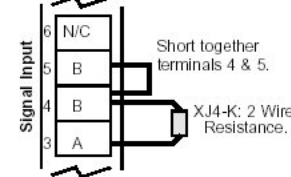
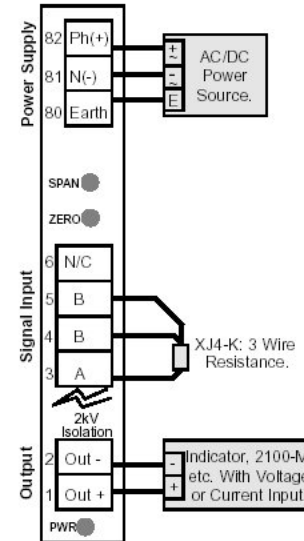

XJ4-N Differential RTD Input.
Connection Example.

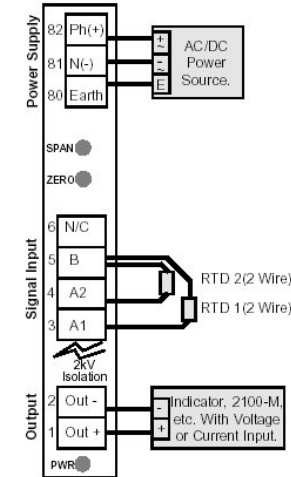

XJ4-R RTD Input.
Connection Example.

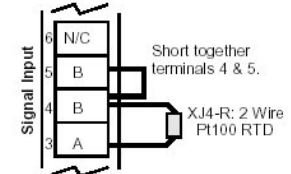
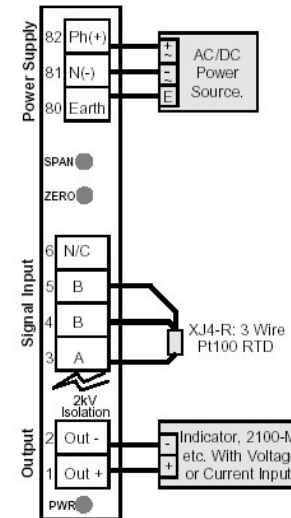

XJ4

XJ4-P Potentiometer Input.
Connection Example.

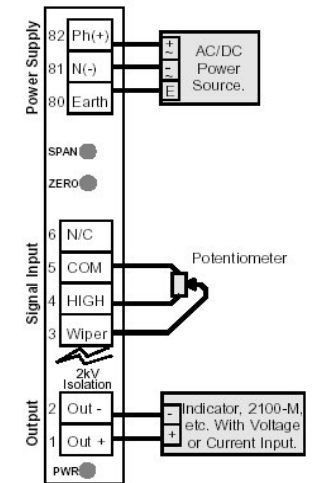

XJ4-T Thermocouple Input.
Connection Example.

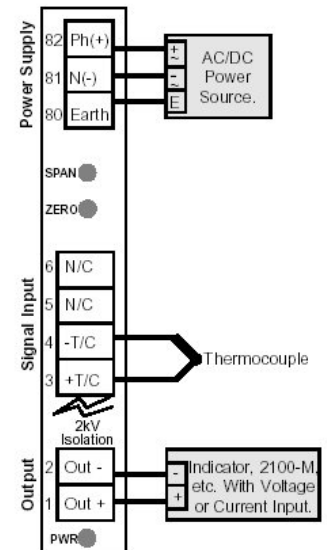

TERMINAL CONFIGURATIONS

XJ2

XJ4

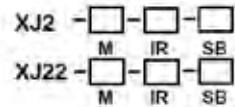

One XJ2 transmitter per enclosure. Select the Model, Input Range and Sensor Break from the table below.

Two XJ2 transmitters per enclosure. Select the Model, Input Range and Sensor Break from table below. Both transmitters must be the same Model and Range.

Ranging Options of XJ2							
Input Model	M	Input Range - IR			Sensor Break	SB	
		Standard	or Specify Within	Min ¹⁾ Max ¹⁾			
Bridge/Strain/gauge	B	0-20mV	0mV to 100mV & Bipolar	6mV	100mV	Upscale U	
DC Current or DC Voltage	D	4-20mA	0mA to 26mA & Bipolar	60µA	26mA	Downscale D	
Resistance	K	0-200Ω	12Ω to 220Ω	12Ω	220Ω		
Differential RTD	N	0-100C	-100C to 520C	-150F to 940F	32C	520C	
Potentiometer	P	0-100%	0% to 100%	6%	100%		
RTD	R	0-100C	-100C to 520C	-150F to 940F	32C	520C	
Thermocouple	T	K: 0-1200C	B: 50C to 1820C E: -270C to 1000C J: -210C to 1200C K: -270C to 1370C L: -200C to 760C N: -270C to 1300C R: -50C to 1760C S: -50C to 1760C T: -270C to 400C U: -200C to 400C	140F to 3310F -454F to 1840F 250F to 2200F -454F to 2500F -330F to 1400F -450F to 2380F -60F to 3200F -60F to 3200F -454F to 760F -330F to 760F	1100C 100C 110C 140C 110C 200C 650C 650C 140C 140C	1820C 1000C 1200C 1370C 1300C 1760C 1760C 400C 400C	

Note 1) Min or Max Input Span Range = Signal High - Signal Low. On any Span range, offsets from 0% to ±0.5% are available.
 Note 2) The XJ2 can be field recalibrated from any Input Range, and Output range to any other Input Range, and Output Range.
 To change the unit to a different Marker (For example from XJ2-D to XJ2-T) ask your local distributor to reconfigure the unit.
 Note 3) Sensor Break option only applies to XJ2-R, XJ2-N, XJ2-R, XJ2-T.
 Note 4) All RTD and Thermocouple models are rangeable for both Celsius and Fahrenheit.

Ordering Examples.

- 1/ XJ2 - B - -10-30mV XJ2: Bridge, -10-30mV Input; 4-20mA Output.
- 2/ XJ2 - D - 0-200mV XJ2: DC, 0-200mV Input; 4-20mA Output.



To order, select the Model, the Input Range, the Output Range, Sensor Break if appropriate, then the Power Supply Setting. Refer to the table below for selections. Other Special Input ranges available on request.

Ranging Options of XJ4									
Input Model	M	Input Range - IR				Output Range - OR			
		Standard	or Specify Within	Min ¹⁾	Max ¹⁾	Voltage	OR	Current	OR
Bridge/Strain/gauge	B	0-20mV	0mV to 100mV & Bipolar	6mV	100mV	0-5V	A	0-10mA	1
DC Current or DC Voltage	D	4-20mA	0mA to 26mA & Bipolar	60µA	26mA	0-10V	B	0-20mA	2
Resistance	K	0-10V	0V to 40V & Bipolar	50mV	40V	1-5V	C	2-10mA	3
Differential RTD	N	0-200Ω	12Ω to 220Ω	12Ω	220Ω	2-10V	D	4-20mA	4
Potentiometer	P	0-100C	-100C to 520C	-150F to 940F	32C	520C	-5-5V	E	-10-10mA
RTD	R	0-100%	0% to 100%	6%	100%	-10-10V	F	-20-20mA	6
Thermocouple	T	K: 0-1200C	B: 50C to 1820C E: -270C to 1000C J: -210C to 1200C K: -270C to 1370C L: -200C to 760C N: -270C to 1300C R: -50C to 1760C S: -50C to 1760C T: -270C to 400C U: -200C to 400C	140F to 3310F -454F to 1840F 250F to 2200F -454F to 2500F -330F to 1400F -450F to 2380F -60F to 3200F -60F to 3200F -454F to 760F -330F to 760F	1100C 100C 110C 140C 110C 200C 650C 650C 140C 140C	1820C 1000C 1200C 1370C 1300C 1760C 1760C 400C 400C			

Note: The XJ4 Thermocouple input is CJC, linear with mV, not linear with temperature.

Note: All RTD and Thermocouple models are rangeable for both Celsius and Fahrenheit.

Sensor Break	SB	POWER SUPPLY	PS
Upscale	U	High Voltage Power Supply: 85-265Vac/dc	H
Downscale	D	Mid Voltage Power Supply: 22-90Vdc	M
		Low Voltage Power Supply: 10-28Vdc	L

Note 1) Min or Max Input Span Range = Signal High - Signal Low. On any Span range, offsets from 0% to ±0.5% can be selected.
 Note 2) The XJ4 can be field recalibrated from any Input Range, and Output range to any other Input Range, and Output Range.
 To change the unit to a different Model (For example from XJ4-D to XJ4-T) ask your local distributor to reconfigure the unit.
 Note 3) Power supply H is field selectable for M and M for H. Power supply L must be ordered separately.
 Note 4) Sensor Break option only applies to XJ4-K, XJ4-N, XJ4-R, XJ4-T only.

Ordering Examples.

- 1/ XJ4 - B - -10-30mV - B - L XJ4: Bridge, -10-30mV Input; 0-10V Output; 10-28Vac/dc PS.
- 2/ XJ4 - D - 0-200mV - 3 - H XJ4: DC, 0-200mV Input; 2-10mA Output; 85-265Vac/dc PS.

Available at



Aegis Sales & Service
 1/119 Delta Street Geebung QLD
 www.aegissales.com.au
 sale@aegissales.com.au
 07 3865 1139